

Grotime®

MANHATTAN COT 30215

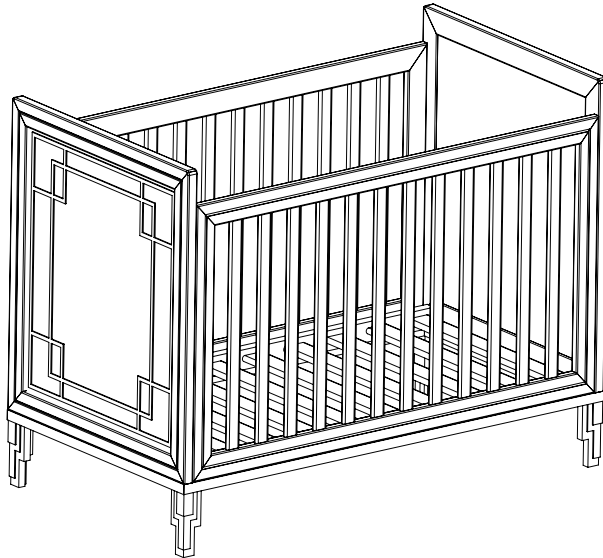

Two adults are required to assemble this cot



Follow all manufacturer's assembly instructions carefully to ensure the safety features of the cot are not compromised

Grotime

110-114 Old Bathurst Rd,
Emu Plains, NSW 2750

P.O. Box 487, Emu Plains,
NSW 2750

Customer Care

Email: customercare@grotime.com.au

AUSTRALIA
1300 799 912
www.grotime.com.au

NEW ZEALAND
+61 2 4728 8067
www.grotime.co.nz



Carefully remove all packaging material and dispose of it according to grade. Be careful not to throw away any components by mistake. After use, dispose of the product in an environmentally friendly manner at your local recycling centre

HARDWARE INVENTORY

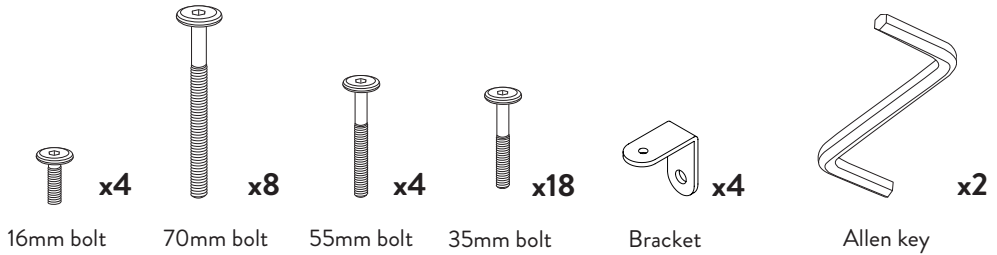

PARTS INVENTORY

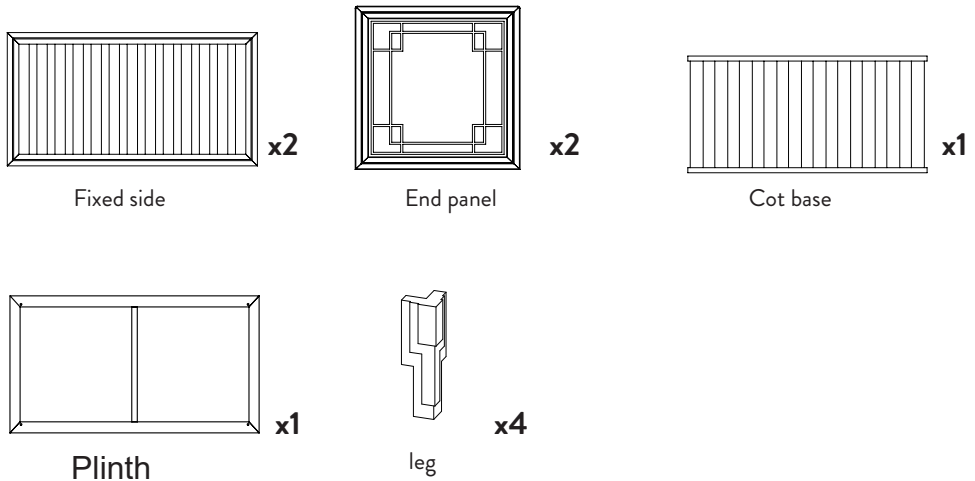

WARNING

BEFORE ASSEMBLING THE COT, ENSURE YOU HAVE A CLEAR AREA ON CARPET OR A THICK BLANKET OR RUG. NEVER ASSEMBLE ON A HARD SURFACE.

STEP 1

Connect the 4 x legs to plinth using 8 x 35mm bolts

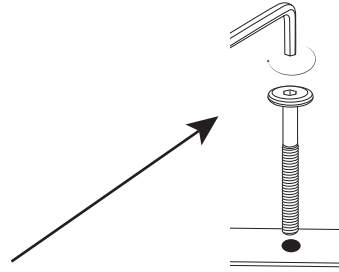
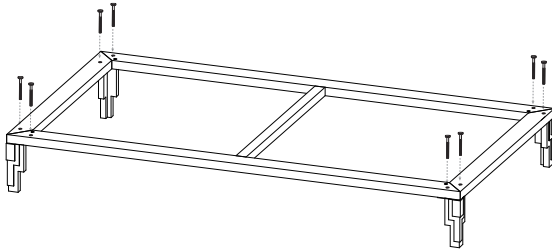
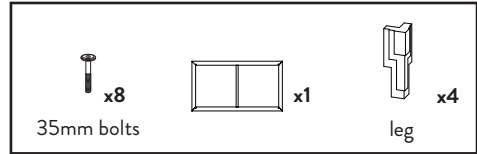

⚠ WARNING ⚠

TO PREVENT FALLS, THE MATTRESS BASE OF THIS COT SHOULD BE ADJUSTED TO THE LOWEST POSITION BEFORE CHILD CAN SIT UP.

STEP 2

Connect 2 x cot ends and 1 x fixed side to the cot plinth using 7 x 35mm bolts

⚠ Do not tighten bolts at this stage

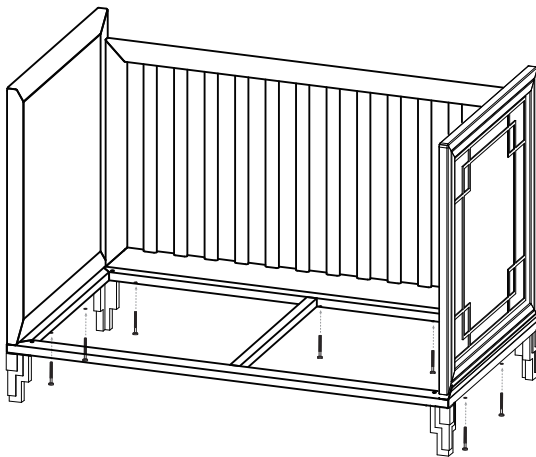
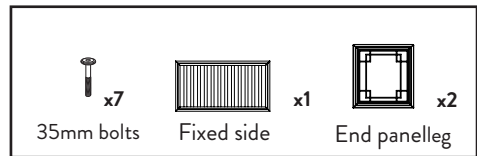

STEP 3

Fasten fixed side to the cot ends
using 4 x 70mm bolts

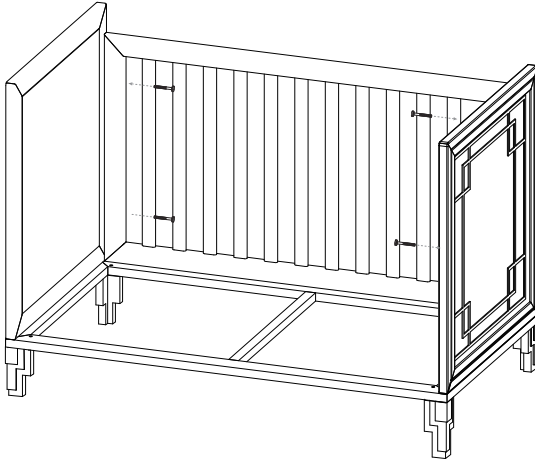
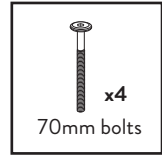

STEP 4

Assemble cot base to plinth
using 4 x 55mm bolts

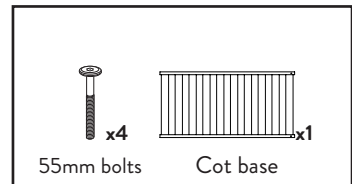

LOW:
Infant level

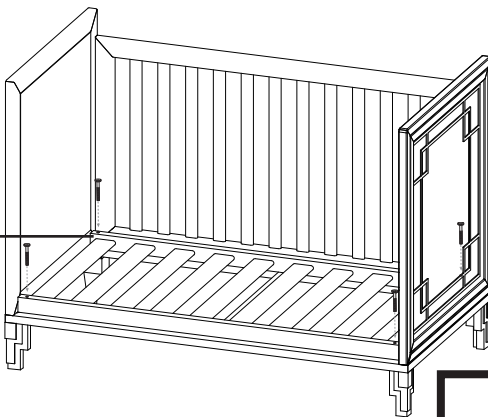

⚠ WARNING ⚠

TO PREVENT FALLS OR
SUFFOCATION, THE MAXIMUM
MATTRESS THICKNESS SHOULD NOT
EXCEED 100MM

STEP 5

Plug finger entrapments using 4 x 16mm bolts

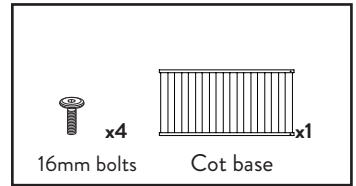
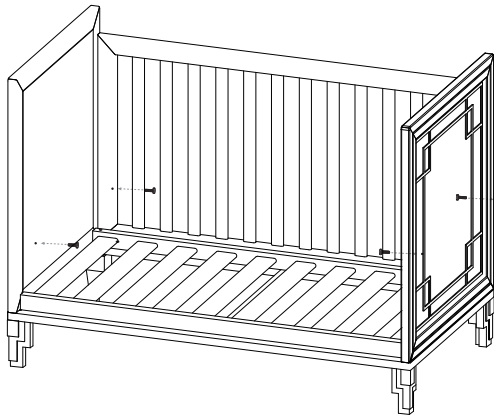

STEP 6

If cot base is being used in infant mode, assemble cot base using

4 x corner bracket and 4 x 16mm bolts as shown

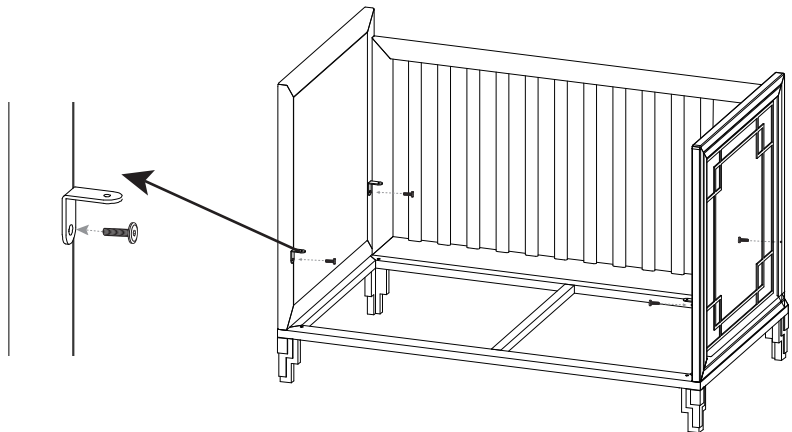
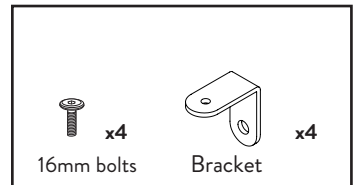

STEP 7

Using 4 x 55mm bolts fix cot base to
4 x bracket (as shown)

! Choose high or
low position for
mattress base

HIGH:
Newborn level

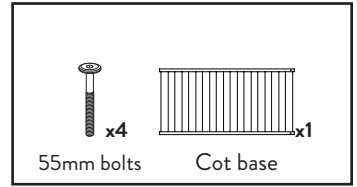
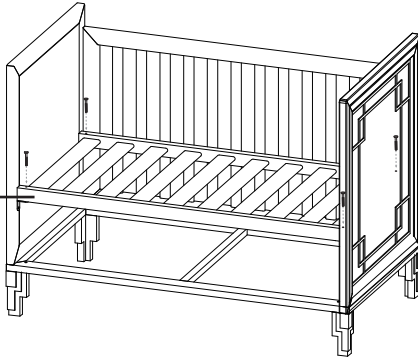

! WARNING !

TO PREVENT FALLS OR
SUFFOCATION, THE MAXIMUM
MATTRESS THICKNESS SHOULD NOT
EXCEED 100MM

STEP 8

Assemble remaining fixed side
using 4 x 70mm bolts

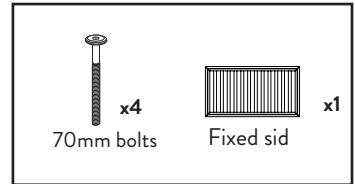

STEP 9

Tighten all bolts

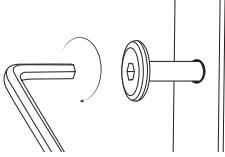

WARNING

ENSURE YOUR CHOSEN LOCATION FOR THE COT IS A REASONABLE DISTANCE FROM CURTAINS, BLINDS, HEATERS, AND POWER POINTS. ALWAYS KEEP MEDICATION, STRING, ELASTIC, SMALL TOYS OR SMALL ITEMS SUCH AS MONEY OUT OF REACH FROM ANY POSITION IN THE COT.

DAY BED CONVERSION

Remove fixed side by reversing Step 8

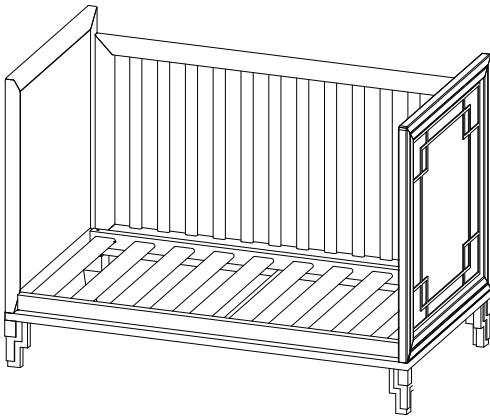

MAINTENANCE AND CARE

Check your cot regularly. Retighten all bolts. For customer care contact Grotime Australia on 1300 799 912; or New Zealand on +61 2 4728 8067.

Do not use abrasive or corrosive agents, or hard brushes for cleaning.

Clean the surface with a lightly dampened, lint free cloth and then wipe with a dry cloth

RECOMMENDED MATTRESS SIZE

This cot has been manufactured for use with a mattress which measures 690mm wide by 1300mm long and 100mm in thickness. The width and length are specified because it is important that the gaps between the mattress and the sides and ends of the cot will not exceed 40mm when the mattress is pushed to one side or end, and 20mm when the mattress is centred in the cot. The thickness of the mattress has been specified to ensure that the depth of the cot is greater than 500mm with the mattress base in the lower position to minimise the risk of a child climbing or falling out of the cot.

5 YEAR NURSERY FURNITURE WARRANTY

1. Our goods come with guarantees that cannot be excluded under the Australian Consumer Law. You are entitled to a replacement or refund for a major failure and for compensation for any other reasonably foreseeable loss or damage. You are also entitled to have the goods repaired or replaced if the goods fail to be of acceptable quality and the failure does not amount to a major failure.
2. In order for your claim to be processed in an efficient timely manner please follow the warranty claims process as outlined below:
 - Fill in the online customer service form found on the following link:
<https://grotime.com.au/customer-service-and-warranty-claims>
 - If you are unable for any reason to process your warranty claim using the online customer care form please call our Grotime customer care team on AU - 1300 799 912 NZ - +61 2 4728 8076 or email customercare@grotime.com.au
 - In order for your claim to be processed you will need to provide to Grotime with an original proof of purchase. For example original retailer purchase receipt, bill of sale, invoice, lay-by docket, credit card receipt or similar proof of purchase.
 - Note: providing attached photographs with your claim will greatly enhance the speed in which your claim is processed.
3. This warranty does not obligate Grotime to bear transportation costs incurred in the repair or replacement of any defective parts and excludes any superficial scratches, dents, scrapes or blemishes to paint work or timber surfaces. This Warranty does not cover faults or defects caused by:
 - unsuitable, improper use or use not in accordance with the manufactures specifications
 - incorrect installation or installation not in accordance with instructions provided
 - normal wear and tear
 - inadequate or complete lack of maintenance
 - chemical, electrochemical or electrical influences or harsh detergents or abrasive cleaners used on product finishes
 - discolouration caused to timber finish by ultra violet (UV) rays or overexposure to direct sunlight
4. To the fullest extent permitted by law, Grotime excludes all liability for damage or injury to any person, damage to any property, and any indirect consequential or other loss or damage.